



I-7022

M-7022

2-ch 12-bit AO Module with Channel-to-Channel Isolation

Features

- 2 Analog Outputs
- Software Selectable Current or Voltage Output
- Configurable Power-on Value and Safe Value Settings
- Open Wire Detection for Current Output
- Readback Voltage or Current
- Programmable Output Slope
- Built-in Dual Watchdog



Introduction

The I-7022 is a 12-bit, 2-channel Analog Output module that is designed for both voltage and current output using the DCON protocol. The I-7022 features 3000 VDC intra-module isolation, and the power source for the current output can be selected as either internal or external via a jumper. Options are also provided to allow power-on and safe values to be set. The M-7022 supports both the Modbus RTU and the DCON protocols which can be configured via software, and all hardware specifications are the same as the I-7022.

System Specifications

Model	I-7022	M-7022
CPU Module		
Watchdog Timer	Module, Communication (Programmable)	
Isolation		
Intra-module Isolation	3000 VDC	
EMS Protection		
EFT (IEC 61000-4-4)	±4 kV for Power Line	
ESD (IEC 61000-4-2)	±4 kV Contact for Each Terminal	
Surge (IEC 61000-4-5)	±0.5 kV for Power Line	
LED Indicators		
Status	1 x Power and Communication	
COM Ports		
Ports	1 x RS-485	
Baud Rate	1200 ~ 115200 bps	
Data Format	(N, 8, 1), (N, 8, 2), (E, 8, 1), (O, 8, 1)	
Protocol	DCON	Modbus RTU, DCON
Power		
Reverse Polarity Protection	Yes	
Input Range	+10 ~ +30 VDC	
Consumption	3.0 W	
Mechanical		
Dimensions (mm)	72 x 123 x 35 (W x L x H)	
Installation	DIN-Rail Mounting	
Environment		
Operating Temperature	-25 ~ +75 °C	
Storage Temperature	-40 ~ +85 °C	
Humidity	10 ~ 95% RH, Non-condensing	

Applications

- Building Automation
- Factory Automation
- Machine Automation
- Remote Maintenance
- Remote Diagnosis
- Testing Equipment

I/O Specifications

Model	I-7022	M-7022
Analog Output		
Channels	2	
Type	Voltage, Current	
Range	Voltage	0 ~ +5 V, 0 ~ +10 V,
	Current	0 ~ +20 mA, +4 ~ +20 mA
Resolution	12-bit	
Accuracy	±0.1% of FSR	
Short Circuit Protection	Yes	
DA Output Response Time	10 ms	
Programmable Output Slope	Voltage	0.0625 ~ 1024.0 V/Second
	Current	0.125 ~ 2048 mA/Second
Open Wire Detection	For Current Only	
Readback Accuracy	±0.5% of FSR	
Current Load Resistance	Internal Power: 500 Ω	
	External Power: 1050 Ω	
Channel-to-Channel Isolation	2 kV	
Power-on Value	Programmable	
Safe Value	Programmable	

Internal I/O Structure

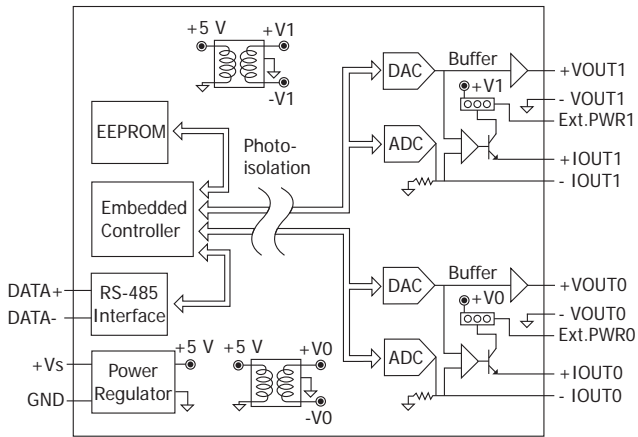

Pin Assignments



Wire Connections

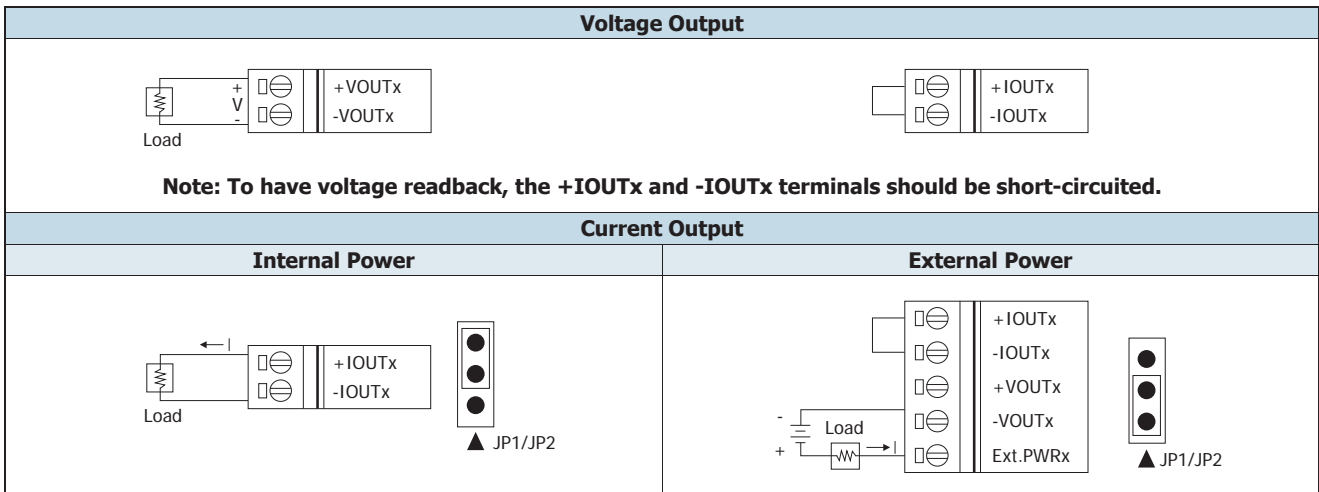

Ordering Information

I-7022 CR	2-ch 12-bit AO Module with Channel-to-Channel Isolation using DCON Protocol (Blue Cover) (RoHS)
I-7022-G CR	2-ch 12-bit AO Module with Channel-to-Channel Isolation using DCON Protocol (Gray Cover) (RoHS)
M-7022-G CR	2-ch 12-bit AO Module with Channel-to-Channel Isolation using DCON and Modbus Protocols (Gray Cover) (RoHS)

Accessories

tM-7520U CR	Tiny Isolated RS-232 to RS-485 Converter (RoHS)
tM-7561 CR	Tiny USB to Isolated RS-485 Converter with CA-USB18 Cable (RoHS)
tM-SG4 CR	RS-485 Pull-high/Pull-low and Termination Resistor Module (RoHS)
I-7514U CR	Isolated 4-channel RS-485 Repeater/Hub/Splitter (Gray Cover) (RoHS)
SG-770 CR	7/14 channel Surge Protector (RoHS)
SG-3000 Series	Signal Conditioning Modules for Thermocouple, RTD, DC Voltage, DC Current and Power Input Transformers