



## EIP-2055

Isolated 8-ch DI and 8-ch DO EtherNet/IP module

### Introduction

The EIP-2055 is a remote digital I/O module with 8 inputs and 8 outputs. It is designed as an EtherNet/IP adapter. With 2 Ethernet ports, the EIP-2055 allows daisy chain connection which permits the flexibility in locating devices, eases installation and lowers infrastructure costs. Users can obtain the I/O as well as the connection status of the EIP-2055 by the LEDs. In addition, ICPDAS provides software utility to easily configure and test the EIP-2000 modules via Ethernet.

### Utility Features

ICPDAS provides the EIP-2000 configuration utility for Windows 2K/XP/Vista and Win 7.

- Network parameters configuration
- Settings for power-on value and safe value.
- DI counters inspection
- Easy test to transmit/receive the I/O status by EtherNet/IP
- Setting files management

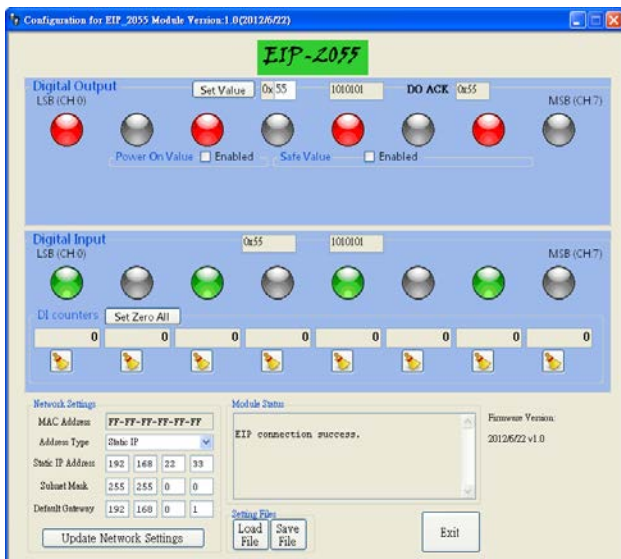

### Features

- Powerful 32-bit MCU handles efficient network traffic
- 10/100 Base-TX Ethernet, RJ-45 x 2 (Auto-negotiating, auto MDI/MDIX, LED Indicators)
- Support ARP, TCP, UDP, ICMP, DHCP, BOOTP and TFTP protocols
- Easy firmware update via Ethernet
- Removable terminal block connector
- LED display to indicate the I/O status
- Built-In I/O — DI/Counter: 8 Channels  
DO: 8 Channels
- Power-On-Value
- Safe-Value
- RoHS compliant



### Wire connection

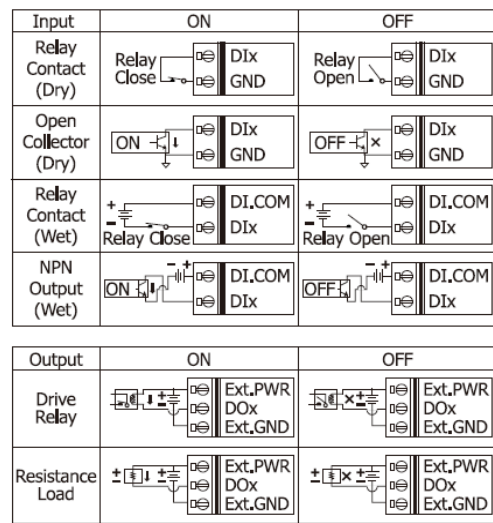

### Dimensions (Units: mm)

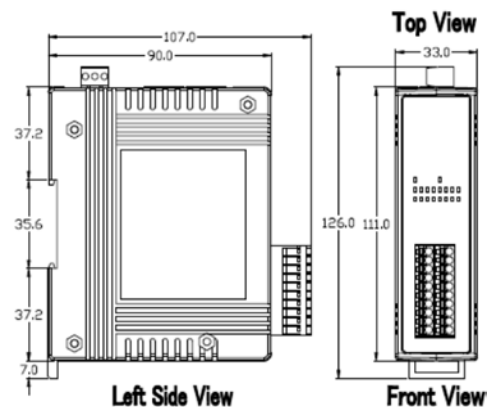

## Hardware Specifications

Digital Input		
Channels	8	
Input Type	Dry Contact: Source, Wet Contact: Sink / Source	
Dry Contact Level	Off Voltage Level: Open	On Voltage Level: Close to GND
Wet Contact Level	Off Voltage Level: +1V max	On Voltage Level: +5 V <sub>DC</sub> ~ +50 V <sub>DC</sub>
Counters	Max. Counts	32-bit (4294967295)
	Max. Input Frequency	3KHz
Input Impedance	7.5 kΩ	
Overvoltage Protection	+70 V <sub>DC</sub>	
Digital Output		
Channels	8	
Type	Open Collector	
Sink/Source(NPN/PNP)	Sink	
Load Voltage	+3.5 ~ +50 V	
Max. Load Current	650 mA per channel	
Overload Protection	1.4 (with short-circuit protect)	
Overvoltage Protection	+60V <sub>DC</sub>	
Communication Interface		
Connector	10/100 Base-TX, 8-pin RJ-45 x 2 . Support daisy chain connection	
Standard Supported	Ethernet/IP(Adapter)	
Power		
Reverse Polarity Protection	Yes	
Power Consumption	2.9W	
Input Voltage Range	10V ~ 30V	
Mechanism		
Installation	DIN-Rail or Wall mounting	
Dimensions	33mm x 127mm x 99mm (W x L x H)	
Environment		
Operating Temperature	-25°C ~ +75°C	
Storage Temperature	-30°C ~ +80°C	
Humidity	10% ~ 90% RH ,Non-condensing	

## Application



## Ordering Information

<b>EIP-2055 CR</b>	Isolated 8-ch DI & 8-ch DO EtherNet/IP Module (RoHS)
--------------------	--