



DC/DC CONVERTER

- 88-360Vdc Wide-range Input
- Width only 65mm
- Efficiency up to 94.6%
- ATEX and IECEx Approved
- Excellent Partial Load Efficiency
- 20% Output Power Reserves
- Safe Hiccup^{PLUS} Overload Mode
- Easy Fuse Tripping due to High Overload Current (typ. 80A for 15ms)
- Minimal Inrush Current Surge
- Full Power Between -25°C and +60°C
- DC-OK Relay Contact
- Reverse Input Polarity Protected
- Current Sharing Feature for Parallel Use
- 3 Year Warranty

GENERAL DESCRIPTION

The Dimension C-Series are cost optimized power supplies and DC/DC converters without compromising quality, reliability and performance. The C-Series is part of the DIMENSION power supply family. The most outstanding features of CPS20.241-D1 are the wide DC-input range, high efficiency, electronic inrush current limitation, wide operational temperature range. The small size is achieved by a synchronous rectification and further technological design details.

The C-Series includes all the essential basic functions. The devices have a power reserve of 20% included, which may even be used continuously at temperatures up to +45°C. Additionally, the CPS20.241-D1 can deliver about 4 times the nominal output current for 15ms which helps to trip fuses on faulty output branches.

High immunity to transients and power surges as well as low electromagnetic emission, a DC-OK relay contact and a large international approval package for a variety of applications makes this unit suitable for nearly every situation.

SHORT-FORM DATA

| | | |
|-------------------|------------------|-------------------|
| Output voltage | DC 24V | |
| Adjustment range | 24 - 28V | |
| Output current | 20A | at 24V, amb <60°C |
| | 24A | at 24V, amb <45°C |
| | 17.1A | at 28V, amb <60°C |
| | 20.6A | at 28V, amb <45°C |
| Output power | 480W | ambient <60°C |
| | 576W | ambient <45°C |
| Output ripple | < 50mVpp | 20Hz to 20MHz |
| AC Input voltage | - | - |
| DC Input voltage | DC 110-300V | ± 20% |
| DC Input current | 4.68 / 1.69A | at 110 / 300Vdc |
| Inrush current | typ. 6 / 4A peak | at 110 / 300Vdc |
| Efficiency | 93.1 / 94.6% | at 110 / 300Vdc |
| Losses | 35.6 / 27.4W | at 110 / 300Vdc |
| Temperature range | -25°C to +70°C | operational |
| Derating | 12W/°C | +60 to +70°C |
| Hold-up time | typ. 26 / 26ms | at 110 / 300Vdc |
| Dimensions | 65x124x127mm | WxHxD |
| Weight | 940g | 2.1lb |

ORDER NUMBERS

| | | |
|-----------------|---------------------|----------------------|
| DC/DC converter | CPS20.241-D1 | 24-28V Standard unit |
| Accessory | ZM2.WALL | Wall mount bracket |
| | ZM13.SIDE | Side mount bracket |
| | YR40.242 | Redundancy module |
| | YR40.245 | Redundancy module |

MARKINGS



INDEX

| | Page | | Page |
|--|------|---|------|
| 1. Intended Use | 3 | 20. Physical Dimensions and Weight | 17 |
| 2. Installation Requirements | 3 | 21. Accessories | 18 |
| 3. AC-Input | 4 | 21.1. ZM2.WALL - Wall Mounting Bracket | 18 |
| 4. DC-Input | 4 | 21.2. ZM13.SIDE - Side Mounting Bracket | 18 |
| 5. Input Inrush Current | 5 | 21.3. Redundancy Modules | 19 |
| 6. Output | 6 | 22. Application Notes | 20 |
| 7. Hold-up Time | 8 | 22.1. Peak Current Capability | 20 |
| 8. DC-OK Relay Contact | 8 | 22.2. Inductive and Capacitive Loads | 21 |
| 9. Efficiency and Power Losses | 9 | 22.3. External Input Protection | 21 |
| 10. Lifetime Expectancy and MTBF | 10 | 22.4. Output Circuit Breakers | 21 |
| 11. Functional Diagram | 10 | 22.5. Parallel Use to Increase Output Power | 22 |
| 12. Terminals and Wiring | 11 | 22.6. Parallel Use for Redundancy | 22 |
| 13. Front Side and User Elements | 12 | 22.7. Series Operation | 23 |
| 14. EMC | 13 | 22.8. Back-feeding Loads | 23 |
| 15. Environment | 14 | 22.9. Charging of Batteries | 24 |
| 16. Protection Features | 15 | 22.10. Use in a Tightly Sealed Enclosure | 24 |
| 17. Safety Features | 15 | 22.11. Mounting Orientations | 25 |
| 18. Dielectric Strength | 16 | | |
| 19. Approvals | 16 | | |

The information presented in this document is believed to be accurate and reliable and may change without notice. No part of this document may be reproduced or utilized in any form without permission in writing from the publisher.

TERMINOLOGY AND ABBREVIATIONS

| | |
|--|---|
| PE and \oplus symbol | PE is the abbreviation for Protective Earth and has the same meaning as the symbol \oplus . |
| Earth, Ground | This document uses the term "earth" which is the same as the U.S. term "ground". |
| T.b.d. | To be defined, value or description will follow later. |
| DC 300V | A figure displayed with the AC or DC before the value represents a nominal voltage with standard tolerances (usually $\pm 15\%$) included. E.g.: DC 12V describes a 12V battery disregarding whether it is full (13.7V) or flat (10V) |
| 300Vdc | A figure with the unit (Vdc) at the end is a momentary figure without any additional tolerances included. |
| may | A key word indicating flexibility of choice with no implied preference. |
| shall | A key word indicating a mandatory requirement. |
| should | A key word indicating flexibility of choice with a strongly preferred implementation. |

1. INTENDED USE

This device is designed for installation in an enclosure and is intended for the general professional use such as in industrial control, office, communication, and instrumentation equipment.

Do not use this DC/DC converter in equipment, where malfunction may cause severe personal injury or threaten human life.

This device is designed for use in hazardous, non-hazardous, ordinary or unclassified locations.

2. INSTALLATION REQUIREMENTS

This device may only be installed and put into operation by qualified personnel.

This device does not contain serviceable parts. The tripping of an internal fuse is caused by an internal defect.

If damage or malfunction should occur during installation or operation, immediately turn power off and send unit to the factory for inspection.

Mount the unit on a DIN-rail so that the terminals are located on the bottom of the unit. For other mounting orientations see de-rating requirements in this document. See chapter 24.13.

This device is designed for convection cooling and does not require an external fan. Do not obstruct airflow and do not cover ventilation grid (e.g. cable conduits) by more than 15%!

Keep the following installation clearances: 40mm on top, 20mm on the bottom, 5mm on the left and right sides are recommended when the device is loaded permanently with more than 50% of the rated power. Increase this clearance to 15mm in case the adjacent device is a heat source (e.g. another power supply).

A disconnecting means shall be provided for the output of the power supplies when used in applications according to CSA C22.2 No 107.1-01.

⚠ WARNING Risk of electrical shock, fire, personal injury or death.

- Do not use the DC/DC converter without proper grounding (Protective Earth). Use the terminal on the input block for earth connection and not one of the screws on the housing.
- Turn power off before working on the device. Protect against inadvertent re-powering.
- Make sure that the wiring is correct by following all local and national codes.
- Do not modify or repair the unit.
- Do not open the unit as high voltages are present inside.
- Use caution to prevent any foreign objects from entering the housing.
- Do not use in wet locations or in areas where moisture or condensation can be expected.
- Do not touch during power-on, and immediately after power-off. Hot surfaces may cause burns.

Notes for use in hazardous location areas:

The power supply is suitable for use in Class I Division 2 Groups A, B, C, D locations and for use in Group II Category 3 (Zone 2) environments and are evaluated according to EN 60079-0:2012 and EN 60079-15:2010.

WARNING EXPLOSION HAZARDS!

Substitution of components may impair suitability for this environment. Do not disconnect the unit or operate the voltage adjustment or S/P jumper unless power has been switched off or the area is known to be non-hazardous.

3. AC-INPUT

Do not operate this DC/DC converter with AC-input voltage. Use the CPS20.241 unit instead.

4. DC-INPUT

Use a battery or a similar DC source. A supply from the intermediate DC-bus of a frequency converter is not recommended and can cause a malfunction or damage the unit.

| | | | |
|---|------|-------------|--|
| DC input | nom. | DC 110-300V | |
| DC input range | min. | 88-360Vdc | short term or with output derating (1%/V) or with reduced ambient temperature, see also Fig. 15-1, no damage between 0 and 88Vdc |
| | min. | 88-100Vdc | |
| Allowed voltage between input to earth (ground) | min. | 360-425Vdc | short term, < 500ms |
| | max. | 360Vdc | continuous, IEC 62103 |
| Slew rate for voltage between input to earth (ground) | | ± 600V | peak value, allowed for transients |
| | max. | 1000V/μs | |
| Allowed input ripple voltage | max. | 50Vpp | 50Hz – 10kHz |
| | | 15Vpp | 10kHz – 50kHz |
| Turn-on voltage | typ. | 85Vdc | steady-state value, see Fig. 4-1 |
| Shut-down voltage | typ. | 37Vdc | steady-state value at 5A load, see Fig. 4-1 |
| | typ. | 50Vdc | steady-state value at 10A load, see Fig. 4-1 |
| | typ. | 69Vdc | steady-state value at 20A load, see Fig. 4-1 |
| | typ. | 69Vdc | steady-state value at 20A load, see Fig. 4-1 |

| | | DC 110V | DC 300V | |
|-------------------|------|----------------|----------------|--|
| Input current | typ. | 4.68A | 1.69A | at 24V, 20A, see Fig. 4-3 |
| Start-up delay | typ. | 1100ms | 830ms | see Fig. 4-2 |
| Rise time | typ. | 85ms | 85ms | at 24V, 20A const. current load, 0mF load capacitance, see Fig. 4-2 |
| | typ. | 150ms | 150ms | at 24V, 20A const. current load, 20mF load capacitance, see Fig. 4-2 |
| Turn-on overshoot | max. | 200mV | 200mV | see Fig. 4-2 |

Fig. 4-1 **Input voltage range**

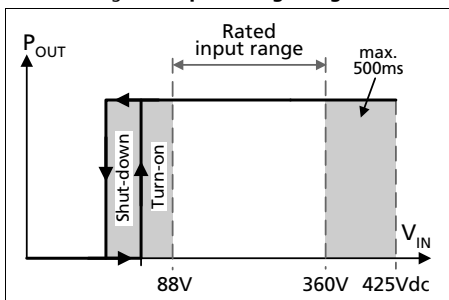

Fig. 4-2 **Turn-on behavior, definitions**

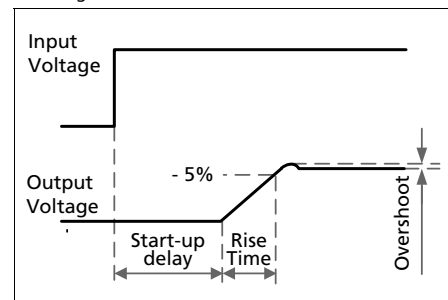
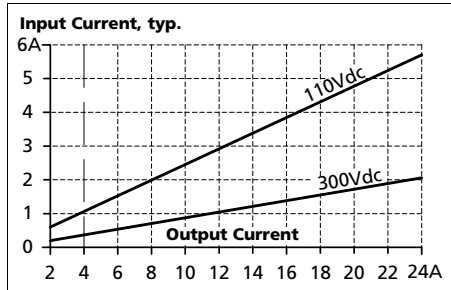

Fig. 4-3 **Input current vs. output load at 24V**



5. INPUT INRUSH CURRENT

An active inrush limitation circuit limits the input inrush current after turn-on of the input voltage and after short input voltage interruptions.

The charging current into EMI suppression capacitors is disregarded in the first microseconds after switch-on.

| | | DC 110V | DC 300V | |
|------------------------------|------|---------------------|---------------------|-------------------------------|
| Inrush current ^{*)} | max. | 13A _{peak} | 10A _{peak} | temperature independent |
| | typ. | 6A _{peak} | 4A _{peak} | temperature independent |
| Inrush energy ^{*)} | max. | 1A ² s | 1A ² s | temperature independent |
| Inrush delay | typ. | 1185ms | 915ms | start-up delay plus rise time |

*) Mains interruptions > 500ms

Fig. 5-1 **Typical input inrush current behaviour at nominal load and 25°C ambient**

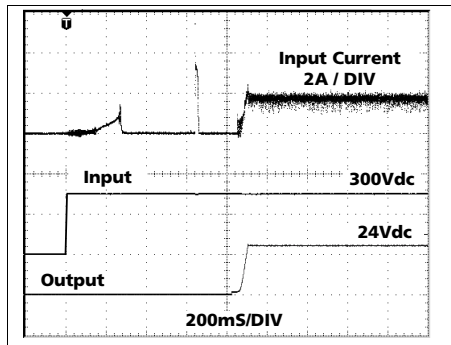

6. OUTPUT

| | | | |
|--------------------------|------|--------------------------------|--|
| Output voltage | nom. | 24V | |
| Adjustment range | min. | 24-28V | guaranteed |
| | max. | 30V****) | at clockwise end position of potentiometer |
| Factory settings | typ. | 24.1V | ±0.2%, at full load, cold unit, in "single use" mode |
| | typ. | 24.1V | ±0.2%, at full load, cold unit, in "parallel use" mode |
| | typ. | 25.1V | at no load, cold unit, in "parallel use" mode |
| Line regulation | max. | 10mV | 88-370Vdc |
| Load regulation | max. | 100mV | in "single use" mode: static value, 0A → 20A; see Fig. 6-1 |
| | typ. | 1000mV | in "parallel use" mode: static value, 0A → 20A, see Fig. 6-2 |
| Ripple and noise voltage | max. | 70mVpp | 20Hz to 20MHz, 50Ohm |
| Output current | nom. | 20A | at 24V, ambient temperature <60°C, see Fig. 6-1 |
| | nom. | 24A*) | at 24V, ambient temperature <45°C, see Fig. 6-1 |
| | nom. | 17.1A | at 28V, ambient temperature <60°C, see Fig. 6-1 |
| | nom. | 20.6A*) | at 28V, ambient temperature <45°C, see Fig. 6-1 |
| | typ. | 80A | up to 15ms, output voltage stays above 20V, see Fig. 6-4. This peak current is available once every five seconds. See chapter 22.1 for more peak current measurements. |
| Output power | nom. | 480W | continuously available |
| | nom. | 576W*) | Power Boost®*) |
| Overload behaviour | | cont. current | output voltage > 13Vdc, see Fig. 6-1 |
| | | Hiccup ^{PLUS} mode**) | output voltage < 13Vdc, see Fig. 6-1 |
| Short-circuit current | min. | 35A***) | load impedance <10mOhm, see Fig. 6-3 |
| | max. | 45A***) | load impedance <10mOhm, see Fig. 6-3 |
| | max. | 15A***) | average (R.M.S.) current, load impedance 50mOhm, see Fig. 6-3 |
| | min. | 70A | < 15ms, load impedance <10mOhm, see Fig. 6-4 |
| | typ. | 100A | < 15ms, load impedance <10mOhm, see Fig. 6-4 |
| Output capacitance | typ. | 7 000µF | included inside the DC/DC converter |

*) **Power Boost**

This power/ current is continuously allowed up to an ambient temperature of 45°C. Above 45°C, do not use this power/ current longer than a duty cycle of 10% and/ or not longer than 1 minute every 10 minutes.

***) **Hiccup^{PLUS} Mode**

At heavy overloads (when output voltage falls below 13V), the DC/DC converter delivers continuous output current for 2s. After this, the output is switched off for approx. 18s before a new start attempt is automatically performed. This cycle is repeated as long as the overload exists. If the overload has been cleared, the device will operate normally. See Fig. 6-3.

****) Discharge current of output capacitors is not included.

*****) This is the maximum output voltage which can occur at the clockwise end position of the potentiometer due to tolerances. It is not guaranteed value which can be achieved. The typical value is about 28.5V (in "single use" mode).

Fig. 6-1 **Output voltage vs. output current, typ.**

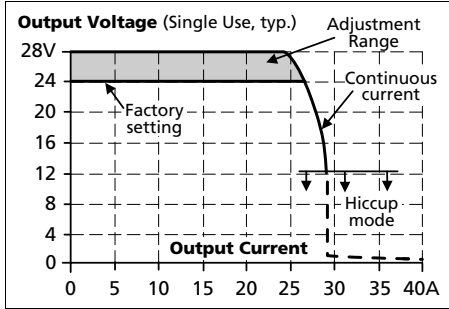

Fig. 6-2 **Output voltage in "parallel use" mode, typ.**

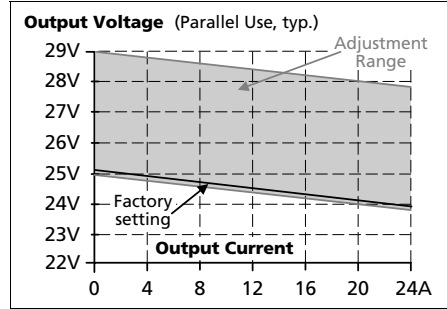

Fig. 6-3 **Short-circuit on output, Hiccup^{PLUS} mode, typ.**

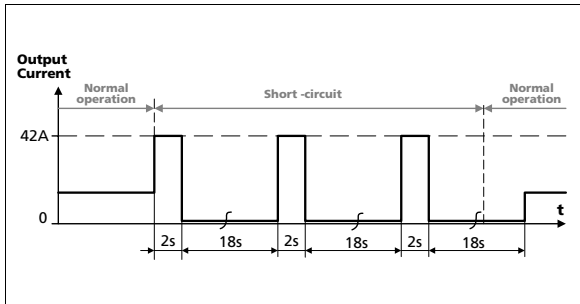
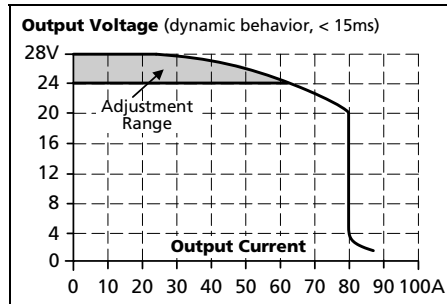

Fig. 6-4 **Dynamic overcurrent capability, typ.**



7. HOLD-UP TIME

The internal capacitor, which supplies the energy for the hold-up time is isolated by a diode to the input voltage. A short on the input line does not discharge the internal hold-up capacitor.

| | | DC 110V | DC 300V | |
|--------------|------|----------------|----------------|---------------------------|
| Hold-up Time | typ. | 65ms | 65ms | at 24V, 10A, see Fig. 7-1 |
| | min. | 54ms | 54ms | at 24V, 10A, see Fig. 7-1 |
| | typ. | 26ms | 26ms | at 24V, 20A, see Fig. 7-1 |
| | min. | 21ms | 21ms | at 24V, 20A, see Fig. 7-1 |

Fig. 7-1 **Hold-up time vs. input voltage**

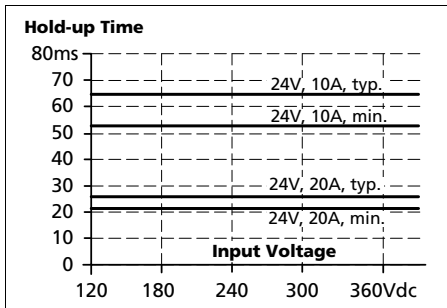
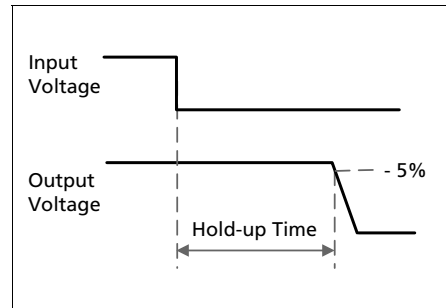

Fig. 7-2 **Shut-down behavior, definitions**



8. DC-OK RELAY CONTACT

This feature monitors the output voltage, which is produced by the DC/DC converter itself. It is independent of a back-fed voltage from a unit connected in parallel to the DC/DC converter output.

| | | | |
|-------------------|---|-----------------------|--|
| Contact closes | As soon as the output voltage reaches 90% of the adjusted output voltage level. | | |
| Contact opens | As soon as the output voltage dips more than 10% below the adjusted output voltage. Short dips will be extended to a signal length of 100ms. Dips shorter than 1ms will be ignored. | | |
| Contact ratings | max. 60Vdc 0.3A, 30Vdc 1A, 30Vac 0.5A | resistive load | |
| | min. 1mA at 5Vdc | min. permissible load | |
| Isolation voltage | See dielectric strength table in section 18. | | |

Fig. 8-1 **DC-ok relay contact behavior**

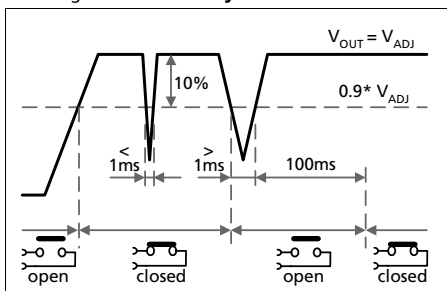

9. EFFICIENCY AND POWER LOSSES

| | | DC 110V | DC 300V | |
|----------------------|------|---------|---------|---|
| Efficiency | typ. | 93.1% | 94.6% | at 24V, 20A |
| | typ. | 93.0% | 94.4% | at 24V, 24A (Power Boost) |
| Average efficiency*) | typ. | 91.8% | 93.4% | 25% at 5A, 25% at 10A, 25% at 15A, 25% at 20A |
| Power losses | typ. | 7.6W | 2.7W | at 24V, 0A |
| | typ. | 18.6W | 15.8W | at 24V, 10A |
| | typ. | 35.6W | 27.4W | at 24V, 20A |
| | typ. | 42.9W | 34.2W | at 24V, 24A (Power Boost) |

*) The average efficiency is an assumption for a typical application where the DC/DC converter is loaded with 25% of the nominal load for 25% of the time, 50% of the nominal load for another 25% of the time, 75% of the nominal load for another 25% of the time and with 100% of the nominal load for the rest of the time.

Fig. 9-1 Efficiency vs. output current at 24V, typ

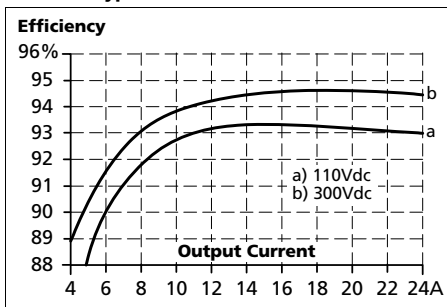

Fig. 9-2 Losses vs. output current at 24V, typ.

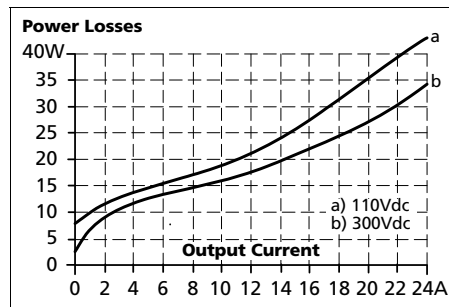

Fig. 9-3 Efficiency vs. input voltage at 24V, 20A, typ.

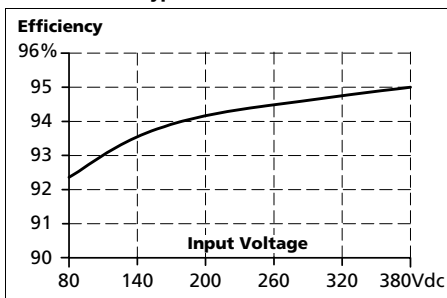
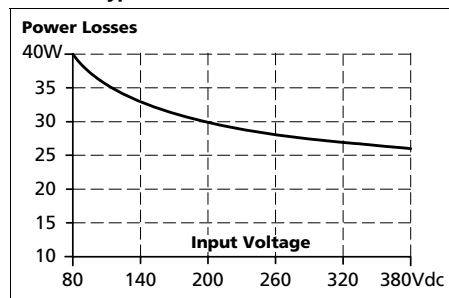

Fig. 9-4 Losses vs. input voltage at 24V, 20A, typ.



10. LIFETIME EXPECTANCY AND MTBF

| | DC 110V | DC 300V | |
|---|------------------------|------------------------|---|
| Lifetime expectancy ^{*)} | 169 000h ^{*)} | 194 000h ^{*)} | at 24V, 10A and 40°C |
| | 478 000h ^{*)} | 549 000h ^{*)} | at 24V, 10A and 25°C |
| | 81 000h | 98 000h | at 24V, 20A and 40°C |
| | 228 000h ^{*)} | 279 000h ^{*)} | at 24V, 20A and 25°C |
| | 48 000h | 56 000h | at 24V, 24A and 40°C |
| | 136 000h ^{*)} | 158 000h ^{*)} | at 24V, 24A and 25°C |
| MTBF ^{**) SN 29500, IEC 61709} | 468 000h | 537 000h | at 24V, 20A and 40°C |
| | 770 000h | 882 000h | at 24V, 20A and 25°C |
| MTBF ^{**) MIL HDBK 217F} | 254 000h | 290 000h | at 24V, 20A and 40°C; Ground Benign GB40 |
| | 355 000h | 395 000h | at 24V, 20A and 25°C; Ground Benign GB25 |
| | 56 000h | 64 000h | at 24V, 20A and 40°C; Ground Fixed GF40 |
| | 75 000h | 86 000h | at 24V, 20A and 25°C; Ground Fixed GF25 |

- *) The **Lifetime expectancy** shown in the table indicates the minimum operating hours (service life) and is determined by the lifetime expectancy of the built-in electrolytic capacitors. Lifetime expectancy is specified in operational hours and is calculated according to the capacitor's manufacturer specification. The manufacturer of the electrolytic capacitors only guarantees a maximum life of up to 15 years (131 400h). Any number exceeding this value is a calculated theoretical lifetime which can be used to compare devices.
- **) **MTBF** stands for **Mean Time Between Failure**, which is calculated according to statistical device failures, and indicates reliability of a device. It is the statistical representation of the likelihood of a unit to fail and does not necessarily represent the life of a product. The MTBF figure is a statistical representation of the likelihood of a device to fail. A MTBF figure of e.g. 1 000 000h means that statistically one unit will fail every 100 hours if 10 000 units are installed in the field. However, it can not be determined if the failed unit has been running for 50 000h or only for 100h.

11. FUNCTIONAL DIAGRAM

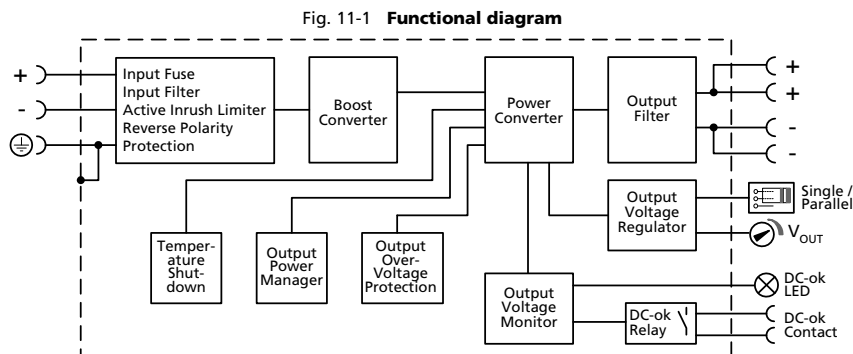

12. TERMINALS AND WIRING

The terminals are IP20 Finger safe constructed and suitable for field- and factory wiring.

| Type | Input and output | DC-OK-Signal |
|-------------------------------|----------------------------------|------------------------------------|
| | screw terminals | spring-clamp terminals |
| Solid wire | 0.5-6mm ² | 0.15-1.5mm ² |
| Stranded wire | 0.5-4mm ² | 0.15-1.5mm ² |
| American Wire Gauge | AWG20-10 | AWG26-14 |
| Max. wire diameter | 2.8mm (including ferrules) | 1.5mm (including ferrules) |
| Wire stripping length | 7mm / 0.28inch | 7mm / 0.28inch |
| Screwdriver | 3.5mm slotted or cross-head No 2 | 3.5mm slotted (to open the spring) |
| Recommended tightening torque | 1Nm, 9lb.in | not applicable |

Instructions:

- Use appropriate copper cables that are designed for minimum operating temperatures of:
 - 60°C for ambient up to 45°C and
 - 75°C for ambient up to 60°C minimum
 - 90°C for ambient up to 70°C minimum.
- Follow national installation codes and installation regulations!
- Ensure that all strands of a stranded wire enter the terminal connection!
- Do not use the unit without PE connection.
- Unused terminal compartments should be securely tightened.
- Ferrules are allowed.

Daisy chaining:

Daisy chaining (jumping from one DC/DC converter output to the next) is allowed as long as the average output current through one terminal pin does not exceed 25A. If the current is higher, use a separate distribution terminal block as shown in Fig. 12-2.

Fig. 12-1 Daisy chaining of outputs

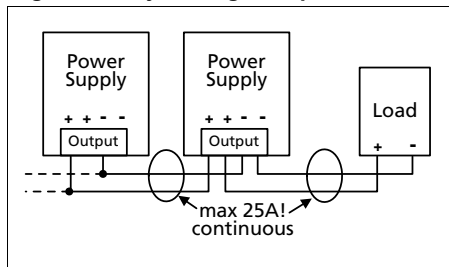
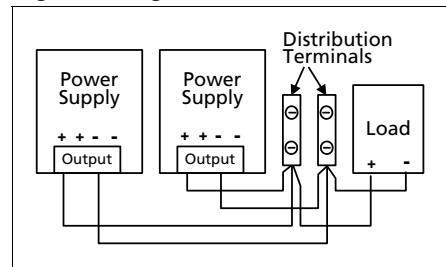
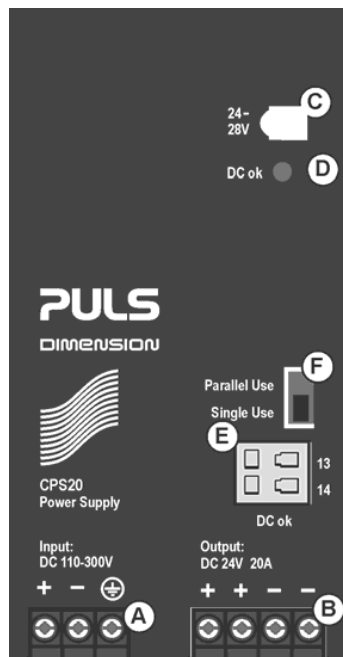

Fig. 12-2 Using distribution terminals



13. FRONT SIDE AND USER ELEMENTS

Fig. 13-1 Front side



A Input Terminals (screw terminals)

- + Positive input
- Negative (return) input
- ⊕ PE (Protective Earth) input

B Output Terminals (screw terminals, two pins per pole)

- + Positive output
- Negative (return) output

C Output voltage potentiometer

Open the flap to adjust the output voltage. Factory set: 24.1V

D DC-OK LED (green)

On, when the output voltage is >90% of the adjusted output voltage

E DC-OK Relay Contact (quick-connect spring-clamp terminals)

The DC-OK relay contact is synchronized with the DC-OK LED. See chapter 8 for details.

F "Parallel Use" "Single Use" selector

Set jumper to "Parallel Use" when DC/DC converter are connected in parallel to increase the output power. In order to achieve a sharing of the load current between the individual DC/DC converter, the "parallel use" regulates the output voltage in such a manner that the voltage at no load is approx. 4% higher than at nominal load. See also chapter 22.5. A missing jumper is equal to a "Single Use" mode.

14. EMC

The DC/DC converter is suitable for applications in industrial environment as well as in residential, commercial and light industry environment without any restrictions. A detailed EMC report is available on request.

| EMC Immunity | | According generic standards: EN 61000-6-1 and EN 61000-6-2 | | |
|--------------------------|--------------|--|-------|-------------|
| Electrostatic discharge | EN 61000-4-2 | contact discharge | 8kV | Criterion A |
| | | air discharge | 15kV | Criterion A |
| Electromagnetic RF field | EN 61000-4-3 | 80MHz-2.7GHz | 20V/m | Criterion A |
| Fast transients (Burst) | EN 61000-4-4 | input lines | 4kV | Criterion A |
| | | output lines | 2kV | Criterion A |
| | | DC-OK signal (coupling clamp) | 2kV | Criterion A |
| Surge voltage on input | EN 61000-4-5 | + → - | 2kV | Criterion A |
| | | + → PE, - → PE | 4kV | Criterion A |
| Surge voltage on output | EN 61000-4-5 | + → - | 1kV | Criterion A |
| | | + / - → PE | 2kV | Criterion A |
| Surge voltage on DC-OK | EN 61000-4-5 | DC-OK signal → PE | 1kV | Criterion A |
| Conducted disturbance | EN 61000-4-6 | 0.15-80MHz | 20V | Criterion A |

Criteria:

A: DC/DC converter shows normal operation behavior within the defined limits.

C: Temporary loss of function is possible. DC/DC converter may shut-down and restarts by itself. No damage or hazards for the DC/DC converter will occur.

| EMC Emission | | According generic standards: EN 61000-6-3 and EN 61000-6-4 | |
|---|----------------------------|--|--|
| Conducted emission input lines | CISPR 16-1-2, CISPR 16-2-1 | limits for DC power port according EN 61000-6-3 fulfilled | |
| Conducted emission output lines ^{*)} | CISPR 16-1-2, CISPR 16-2-1 | limits for DC power port according EN 61000-6-3 fulfilled | |
| Radiated emission | EN 55011, EN 55022 | Class B | |

This device complies with FCC Part 15 rules.

Operation is subjected to following two conditions: (1) this device may not cause harmful interference, and (2) this device must accept any interference received, including interference that may cause undesired operation.

*) for information only, not mandatory for EN 61000-6-3

| Switching Frequencies | | The DC/DC converter has two converters with two different switching frequencies included. | |
|------------------------------|-----------------|---|--|
| Switching frequency 1 | 70kHz to 130kHz | PFC converter, input voltage and output power dependent | |
| Switching frequency 2 | 80kHz to 140kHz | Main converter, output power dependent | |

15. ENVIRONMENT

| | | |
|---------------------------------------|--|---|
| Operational temperature ^{*)} | -25°C to +70°C (-13°F to 158°F) | reduce output power according Fig. 15-1 |
| Storage temperature | -40 to +85°C (-40°F to 185°F) | for storage and transportation |
| Output de-rating | 6.4W/°C 12W/°C | 45°C to 60°C (113°F to 140°F) 60°C to 70°C (140°F to 158°F) |
| Humidity ^{**)} | 5 to 95% r.h. | IEC 60068-2-30 |
| Vibration sinusoidal | 2-17.8Hz: ±1.6mm; 17.8-500Hz: 2g ^{***)} 2 hours / axis | IEC 60068-2-6 |
| Shock | 30g 6ms, 20g 11ms ^{***)} 3 bumps / direction, 18 bumps in total | IEC 60068-2-27 |
| Altitude | 0 to 2000m (0 to 6 560ft) 2000 to 6000m (6 560 to 20 000ft) | without any restrictions reduce output power or ambient temperature, see Fig. 15-2 IEC 62103, EN 50178, overvoltage category II |
| Altitude de-rating | 30W/1000m or 5°C/1000m | > 2000m (6500ft), see Fig. 15-2 |
| Over-voltage category | III II | IEC 62103, EN 50178, altitudes up to 2000m altitudes from 2000m to 6000m |
| Degree of pollution | 2 | IEC 62103, EN 50178, not conductive |
| LABS compatibility | The unit does not release any silicone or other LABS-critical substances and is suitable for use in paint shops. | |
| Audible noise | At load currents below 2A some audible noise will be emitted from the DC/DC converter | |

*) Operational temperature is the same as the ambient temperature and is defined as the air temperature 2cm below the unit.

**) Do not energize while condensation is present

***) Tested in combination with DIN-Rails according to EN 60715 with a height of 15mm and a thickness of 1.3mm and standard orientation. Higher levels allowed when using the wall mounting bracket ZM2.WALL

Fig. 15-1 Output current vs. ambient temp.

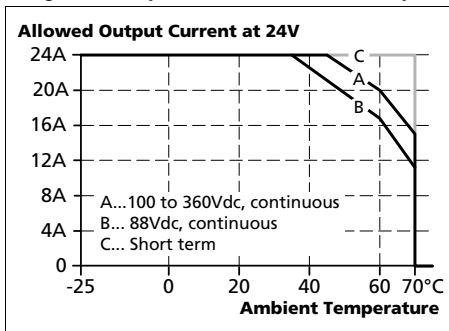
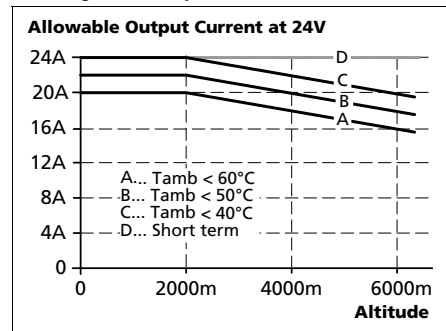

Fig. 15-2 Output current vs. altitude



16. PROTECTION FEATURES

| | | |
|-----------------------------------|---|--|
| Output protection | Electronically protected against overload, no-load and short-circuits ^{*)} | |
| Output over-voltage protection | typ. 30.5Vdc max. 32Vdc | In case of an internal DC/DC converter defect, a redundant circuit limits the maximum output voltage. The output shuts down and automatically attempts to restart. |
| Degree of protection | IP 20 | EN/IEC 60529 Caution: For use in a controlled environment according to CSA 22.2 No 107.1-01. |
| Penetration protection | > 5mm | e.g. screws, small parts |
| Over-temperature protection | yes | Output shut-down with automatic restart |
| Input transient protection | MOV (Metal Oxide Varistor) | |
| Internal input fuse | DC suitable fuse included | not user replaceable |
| Reverse input polarity protection | yes | unit does not start, no signalling |

*) In case of a protection event, audible noise may occur.

17. SAFETY FEATURES

| | | |
|---|--|---|
| Input / output separation ^{*)} | SELV PELV double or reinforced insulation | IEC/EN 60950-1 IEC/EN 60204-1, EN 50178, IEC 62103, IEC 60364-4-41 |
| Class of protection | I | PE (Protective Earth) connection required |
| Isolation resistance | > 5MΩ | input to output, 500Vdc |
| PE resistance | < 0.1Ω | |
| Touch current (leakage current) | The leakage current which is produced by the DC/DC converter itself depends on the input voltage ripple and need to be investigated in the final application. For a smooth DC input voltage, the produced leakage current is less than 100µA. | |

*) double or reinforced insulation

18. DIELECTRIC STRENGTH

The output voltage is floating and has no ohmic connection to the ground. Type and factory tests are conducted by the manufacturer. Field tests may be conducted in the field using the appropriate test equipment which applies the voltage with a slow ramp (2s up and 2s down). Connect all input-terminals together as well as all output poles before conducting the test. When testing, set the cut-off current settings to the value in the table below.

Fig. 18-1 Dielectric strength

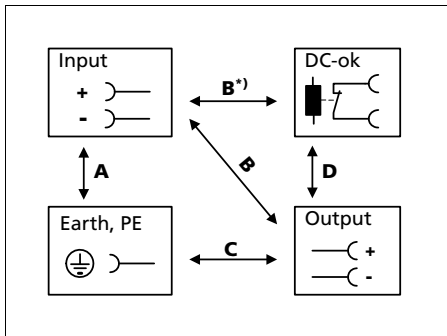

| | | A | B | C | D |
|-------------------------|-----|----------|----------|----------|----------|
| Type test | 60s | 2500Vac | 3000Vac | 1000Vac | 500Vac |
| Factory test | 5s | 2500Vac | 2500Vac | 500Vac | 500Vac |
| Field test | 5s | 2000Vac | 2000Vac | 500Vac | 500Vac |
| Cut-off current setting | | > 15mA | > 15mA | > 20mA | > 1mA |

To fulfil the PELV requirements according to EN60204-1 § 6.4.1, we recommend that either the + pole, the - pole or any other part of the output circuit shall be connected to the protective earth system. This helps to avoid situations in which a load starts unexpectedly or can not be switched off when unnoticed earth faults occur.

B*) When testing input to DC-OK ensure that the max. voltage between DC-OK and the output is not exceeded (column D). We recommend connecting DC-OK pins and the output pins together when performing the test.

19. APPROVALS

EC Declaration of Conformity



The CE mark indicates conformance with the

- EMC directive 2004/108/EC,
- Low-voltage directive (LVD) 2006/95/EC,
- RoHS directive 2011/65/EU and the
- ATEX directive 94/9/EC (for use in explosive atmospheres).

IEC 60950-1
2nd Edition



CB Scheme,
Information Technology Equipment

UL 508



Listed for use as Industrial Control Equipment;
U.S.A. (UL 508) and Canada (C22.2 No. 107-1-01);
E-File: E198865

UL 60950-1
2nd Edition



Recognized for use as Information Technology Equipment,
Level 5; U.S.A. (UL 60950-1) and Canada (C22.2 No. 60950-1);
E-File: E137006
Applicable for altitudes up to 2000m.

ANSI / ISA 12.12.01-2007
Class I Div 2



Recognized for use in Hazardous Location Class I Div 2 T3
Groups A,B,C,D systems; U.S.A. (ANSI / ISA 12.12.01-2007) and
Canada (C22.2 No. 213-M1987)

EN 60079-0, EN 60079-15
ATEX



Approval for use in hazardous locations Zone 2 Category 3G.
Number of ATEX certificate: EPS 13 ATEX 1 555 X
The DC/DC converter must be built-in in an IP54 enclosure.

IEC 60079-0, IEC 60079-15



Suitable for use in Class 1 Zone 2 Groups IIa, IIb and IIc
locations. Number of IECEx certificate: IECEx EPS 13.0016X

GOST R



Certificate of Conformity for Russia and other GUS countries

20. PHYSICAL DIMENSIONS AND WEIGHT

| | |
|-------------------------|---|
| Weight | 940g / 2.1lb |
| DIN-Rail | Use 35mm DIN-rails according to EN 60715 or EN 50022 with a height of 7.5 or 15mm. The DIN-rail height must be added to the unit depth (127mm) to calculate the total required installation depth. |
| Installation Clearances | See chapter 2 |

Fig. 20-1 **Front view**

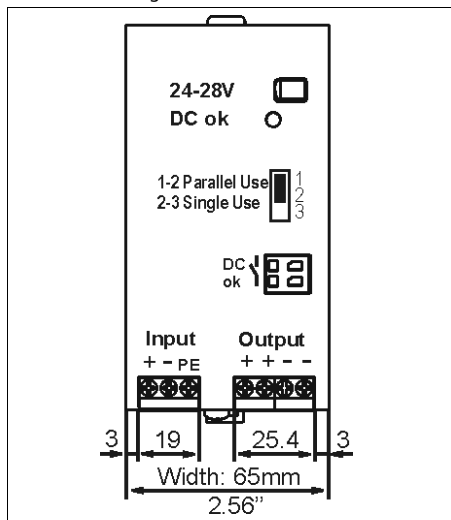
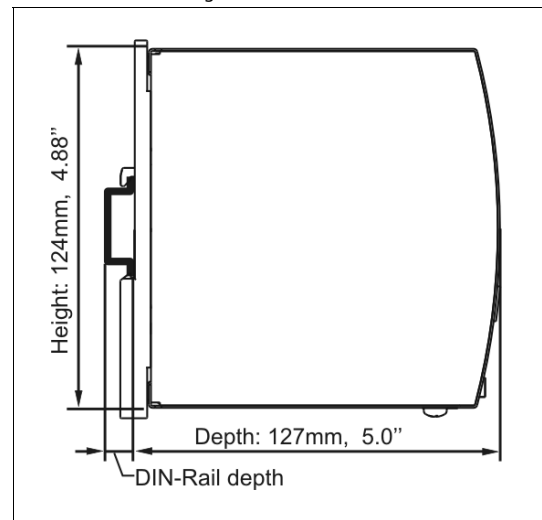

Fig. 20-2 **Side view**



21. ACCESSORIES

21.1. ZM2.WALL - WALL MOUNTING BRACKET

This bracket is used to mount the DC/DC converter onto a flat surface without utilizing a DIN-Rail.

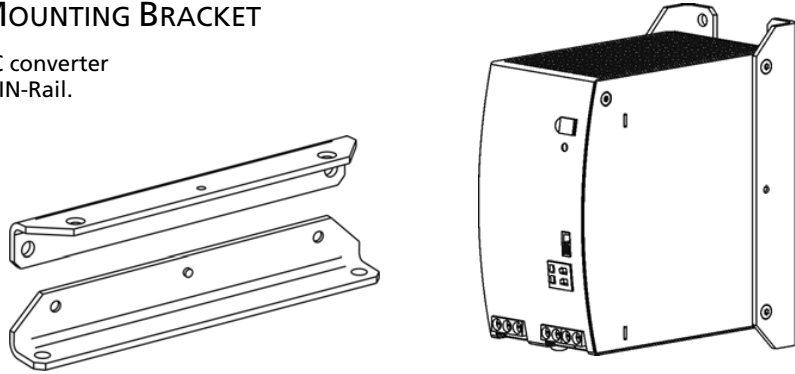

21.2. ZM13.SIDE - SIDE MOUNTING BRACKET

This bracket is used to mount DIMENSION units sideways with or without utilizing a DIN-Rail. The two aluminum brackets and the black plastic slider of the unit have to be detached, so that the steel brackets can be mounted.

For sideways DIN-rail mounting, the removed aluminum brackets and the black plastic slider need to be mounted on the steel bracket.

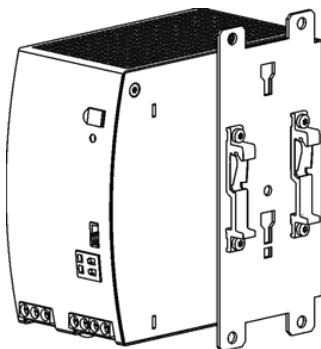

Side mounting with DIN-rail brackets

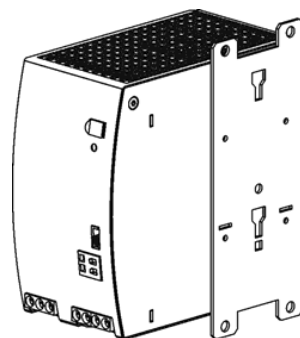

Side mounting without DIN-rail brackets

21.3. REDUNDANCY MODULES

YR40.242 – (2x 20A Inputs, 1x 40A output)



The YR40.242 is equipped with two input channels, which are individually decoupled by utilizing mosfet technology. Using mosfets instead of diodes reduces the heat generation and the voltage drop between input and output. The YR40.242 does not require an additional auxiliary voltage and is self-powered even in case of a short circuit across the output. Due to the low power losses, the unit is very slender and only requires 36mm width on the DIN-rail.

YR40.245 – (1x 40A input, 1x 40A output)



The YR40.245 is a 40A single channel redundancy module, which is equipped with a plug connector on the output. The plug connector allows replacing the power supply or the redundancy module while the system is running. The plug connector avoids that the output wires can touch and short the load circuit.

The YR40.245 is very slender and only requires 46mm width on the DIN-rail. It also utilizes mosfet technology instead of diodes for low heat generation and a minimal voltage drop between input and output. It does not require an additional auxiliary voltage and is self-powered even in case of a short circuit across the output.

Fig. 21-1 Typical 1+1 Redundant configuration for 20A with a dual redundancy module

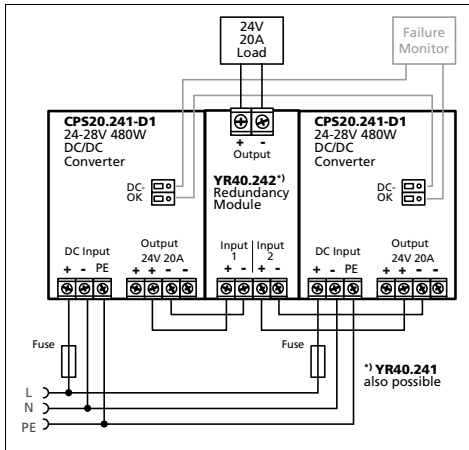
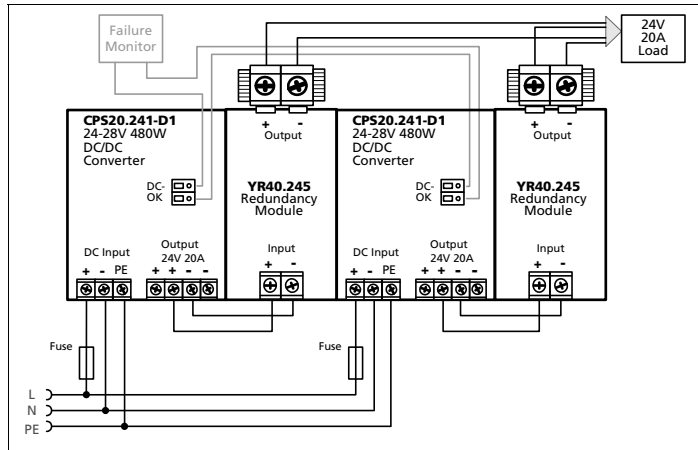

Fig. 21-2 Typical N+1 or 1+1 Redundant configuration for 20A with multiple YR40.245 redundancy modules



22. APPLICATION NOTES

22.1. PEAK CURRENT CAPABILITY

The DC/DC converter can deliver peak currents (up to several milliseconds) which are higher than the specified short term currents. This helps to start current demanding loads. Solenoids, contactors and pneumatic modules often have a steady state coil and a pick-up coil. The inrush current demand of the pick-up coil is several times higher than the steady-state current and usually exceeds the nominal output current (including the PowerBoost). The same situation applies when starting a capacitive load.

The peak current capability also ensures the safe operation of subsequent circuit breakers of load circuits. The load branches are often individually protected with circuit breakers or fuses. In case of a short or an overload in one branch circuit, the fuse or circuit breaker need a certain amount of over-current to open in a timely manner. This avoids voltage loss in adjacent circuits.

The extra current (peak current) is supplied by the power converter and the built-in large sized output capacitors of the DC/DC converter. The capacitors get discharged during such an event, which causes a voltage dip on the output. The following two examples show typical voltage dips:

Fig. 22-1 **Peak load with 2x the nominal current for 50ms, typ.**

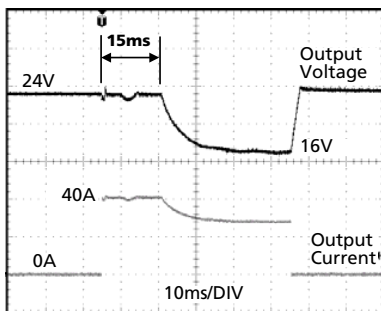

40A Peak load (resistive) for 50ms
Output voltage dips from 24V to 16V.

Fig. 22-2 **Peak load with 5x the nominal current for 5ms, typ.**

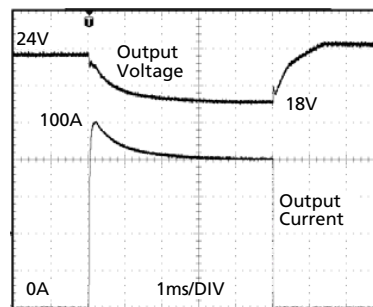

100A Peak load (resistive) for 5ms
Output voltage dips from 24V to 18V.

Fig. 22-3 **90A Peak load, typ.**

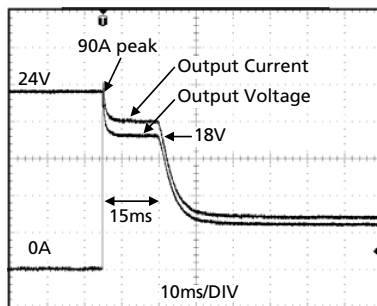

High Overload Current (typ. 90A for 15ms) enables easy fuse tripping

Please note: The DC-OK relay triggers when the voltage dips more than 10% for longer than 1ms.

| | | | |
|---------------------------|------|-------------------|---------------------------------|
| Peak current voltage dips | typ. | from 24V to 16V | at 40A for 50ms, resistive load |
| | typ. | from 24V to 18.5V | at 100A for 2ms, resistive load |
| | typ. | from 24V to 18V | at 100A for 5ms, resistive load |

22.2. INDUCTIVE AND CAPACITIVE LOADS

The unit is designed to supply any kind of loads, including capacitive and inductive loads. If extreme large capacitors, such as EDLCs (electric double layer capacitors or "UltraCaps") with a capacitance > 0.5F are connected to the output, the unit might charge the capacitor in the Hiccup^{PLUS}-mode (see chapter 6).

22.3. EXTERNAL INPUT PROTECTION

The unit is tested and approved for branch circuits up to 30A (UL) and 32A (IEC). An external protection is only required if the supplying branch has an ampacity greater than this. Provided, that the negative pole is grounded. If the positive pole is grounded, an additional external fast-acting input fuse in the negative input is required (E.g. 8A KLKD fuse from Littelfuse or a comparable UL-Listed fuse with the same ratings and characteristics). Otherwise the status of the UL approvals becomes void.

Check also local codes and local requirements. In some countries local regulations might apply.

If an external fuse is necessary or utilized, minimum requirements need to be considered to avoid nuisance tripping of the circuit breaker. A minimum value of 10A B- or C-Characteristic breaker should be used.

22.4. OUTPUT CIRCUIT BREAKERS

Standard miniature circuit breakers (MCB's or UL1077 circuit breakers) are commonly used for AC-supply systems and may also be used on 24V branches.

MCB's are designed to protect wires and circuits. If the ampere value and the characteristics of the MCB are adapted to the wire size that is used, the wiring is considered as thermally safe regardless of whether the MCB opens or not.

To avoid voltage dips and under-voltage situations in adjacent 24V branches which are supplied by the same source, a fast (magnetic) tripping of the MCB is desired. A quick shutdown within 10ms is necessary corresponding roughly to the ride-through time of PLC's. This requires DC/DC converters with high current reserves and large output capacitors. Furthermore, the impedance of the faulty branch must be sufficiently small in order for the current to actually flow. The best current reserve in the DC/DC converter does not help if Ohm's law does not permit current flow. The following table has typical test results showing which B- and C-Characteristic MCBs magnetically trip depending on the wire cross section and wire length.

Fig. 22-4 Test circuit

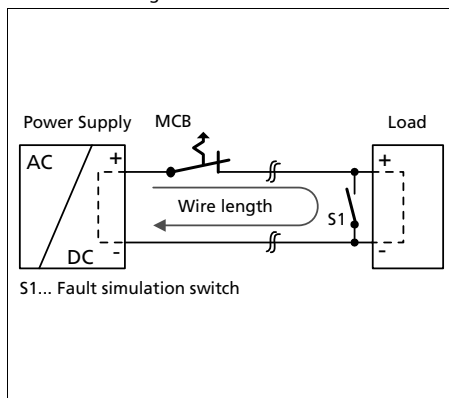

Maximal wire length^{*)} for a fast (magnetic) tripping:

| | 0.75mm ² | 1.0mm ² | 1.5mm ² | 2.5mm ² |
|--------------|---------------------|--------------------|--------------------|--------------------|
| C-2A | 29m | 40m | 56m | 82m |
| C-3A | 26m | 35m | 50m | 77m |
| C-4A | 21m | 28m | 36m | 53m |
| C-6A | 8m | 10m | 14m | 25m |
| C-8A | 4m | 7m | 11m | 18m |
| C-10A | 1m | 2m | 3m | 6m |
| B-6A | 17m | 24m | 35m | 53m |
| B-10A | 12m | 16m | 23m | 32m |
| B-13A | 9m | 13m | 20m | 29m |
| B-16A | 4m | 7m | 9m | 17m |
| B-20A | 1m | 1m | 2m | 2m |

*) Don't forget to consider twice the distance to the load (or cable length) when calculating the total wire length (+ and - wire).

22.5. PARALLEL USE TO INCREASE OUTPUT POWER

CPS20.241-D1 DC/DC converter can be paralleled to increase the output power. The output voltage of all DC/DC converters shall be adjusted to the same value ($\pm 100\text{mV}$) in "Single use" mode with the same load conditions on all units, or the units can be left with the factory settings. After the adjustments, the jumper on the front of the unit shall be moved from "Single use" to "Parallel use", in order to achieve load sharing. The "Parallel use" mode regulates the output voltage in such a manner that the voltage at no load is approx. 4% higher than at nominal load. See also chapter 6. If no jumper is plugged in, the unit is in "Single use" mode. Factory setting is "Single use" mode.

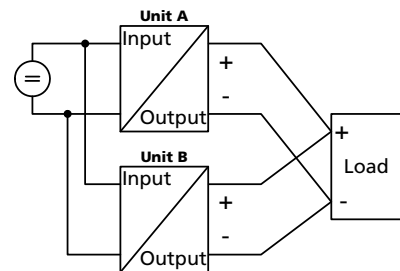

If more than three units are connected in parallel, a fuse or circuit breaker with a rating of 30A or 32A is required on each output. Alternatively, a diode or redundancy module can also be utilized.

Energize all units at the same time to avoid the overload Hiccup^{PLUS} mode. It also might be necessary to cycle the input power (turn-off for at least five seconds), if the output was in Hiccup^{PLUS} mode due to overload or short circuits and the required output current is higher than the current of one unit.

Keep an installation clearance of 15mm (left / right) between two DC/DC converters and avoid installing the DC/DC converters on top of each other. Do not use DC/DC converters in parallel in mounting orientations other than the standard mounting orientation (terminals on bottom of the unit) or in any other condition where a derating of the output current is required (e.g. altitude, above 60°C, ...).

Pay attention that EMI and inrush current will increase when using multiple DC/DC converters.

22.6. PARALLEL USE FOR REDUNDANCY

DC/DC converters can be paralleled for redundancy to gain higher system availability. Redundant systems require a certain amount of extra power to support the load in case one DC/DC converter unit fails. The simplest way is to put two DC/DC converters in parallel. This is called a 1+1 redundancy. In case one DC/DC converter unit fails, the other one is automatically able to support the load current without any interruption. Redundant systems for a higher power demand are usually built in a N+1 method. E.g. five DC/DC converter, each rated for 20A are paralleled to build a 80A redundant system. For N+1 redundancy the same restrictions apply as for increasing the output power, see also section 22.5.

Please note: This simple way to build a redundant system does not cover failures such as an internal short circuit in the secondary side of the DC/DC converter. In such a case, the defective unit becomes a load for the other DC/DC converters and the output voltage can not be maintained any more. This can be avoided by utilizing redundancy modules, which have decoupling devices (diodes or mosfets) included. Further information and wiring configurations can be found in chapter 21.3.

Recommendations for building redundant power systems:

- Use separate input fuses for each DC/DC converter.
- Set the DC/DC converter into "Parallel use" mode.
- Monitor the individual DC/DC converter units. Therefore, use the DC-OK relay contact of the CPS20 DC/DC converter.
- It is desirable to set the output voltages of all units to the same value ($\pm 100\text{mV}$) or leave it at the factory setting.

22.7. SERIES OPERATION

DC/DC converters of the same type can be connected in series for higher output voltages. It is possible to connect as many units in series as needed, providing the sum of the output voltage does not exceed 150Vdc. Voltages with a potential above 60Vdc are not SELV any more and can be dangerous. Such voltages must be installed with a protection against touching.

Earthing of the output is required when the sum of the output voltage is above 60Vdc.

Avoid return voltage (e.g. from a decelerating motor or battery) which is applied to the output terminals.

Keep an installation clearance of 15mm (left / right) between two DC/DC converters and avoid installing the DC/DC converters on top of each other. Do not use DC/DC converters in series in mounting orientations other than the standard mounting orientation (terminals on bottom of the unit).

Pay attention that EMI and inrush current will increase when using multiple DC/DC converters.

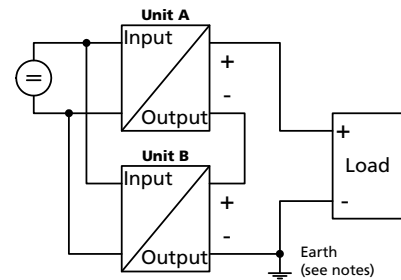

22.8. BACK-FEEDING LOADS

Loads such as decelerating motors and inductors can feed voltage back to the DC/DC converter. This feature is also called return voltage immunity or resistance against Back- E.M.F. (Electro Magnetic Force).

This DC/DC converter is resistant and does not show malfunctioning when a load feeds back voltage to the DC/DC converter. It does not matter whether the DC/DC converter is on or off.

The maximum allowed feed-back-voltage is 35Vdc. The absorbing energy can be calculated according to the built-in large sized output capacitor which is specified in chapter 6.

22.9. CHARGING OF BATTERIES

The DC/DC converter can be used to charge lead-acid or maintenance free batteries. (Two 12V batteries in series)

Instructions for charging batteries:

- a) Set output voltage (measured at no load and at the battery end of the cable) very precisely to the end-of-charge voltage.

| | | | | |
|-----------------------|-------|-------|--------|-------|
| End-of-charge voltage | 27.8V | 27.5V | 27.15V | 26.8V |
| Battery temperature | 10°C | 20°C | 30°C | 40°C |

- b) Use a 30A or 32A circuit breaker (or blocking diode) between the DC/DC converter and the battery.
c) Ensure that the output current of the DC/DC converter is below the allowed charging current of the battery.
d) Use only matched batteries when putting 12V types in series.
e) The return current to the DC/DC converter (battery discharge current) is typ. 23mA when the DC/DC converter is switched off (except in case a blocking diode is utilized).

22.10. USE IN A TIGHTLY SEALED ENCLOSURE

When the DC/DC converter is installed in a tightly sealed enclosure, the temperature inside the enclosure will be higher than outside. In such situations, the inside temperature defines the ambient temperature for the DC/DC converter.

The following measurement results can be used as a reference to estimate the temperature rise inside the enclosure.

The DC/DC converter is placed in the middle of the box, no other heat producing items are inside the box

| | |
|--------------------------------|--|
| Enclosure: | Rittal Typ IP66 Box PK 9522 100, plastic, 254x180x165mm |
| Load: | 24V, 16A; (=80%) load is placed outside the box |
| Input: | 300Vdc |
| Temperature inside enclosure: | 51.5°C (in the middle of the right side of the DC/DC converter with a distance of 2cm) |
| Temperature outside enclosure: | 25.0°C |
| Temperature rise: | 26.5K |

22.11. MOUNTING ORIENTATIONS

Mounting orientations other than all terminals on the bottom require a reduction in continuous output power or a limitation in the maximum allowed ambient temperature. The amount of reduction influences the lifetime expectancy of the DC/DC converter. Therefore, two different derating curves for continuous operation can be found below:

Curve A1 Recommended output current.

Curve A2 Max allowed output current (results in approximately half the lifetime expectancy of A1).

Fig. 22-5
Mounting Orientation A
(Standard orientation)

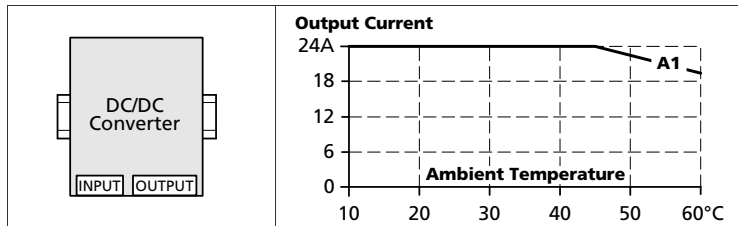

Fig. 22-6
Mounting Orientation B
(Upside down)

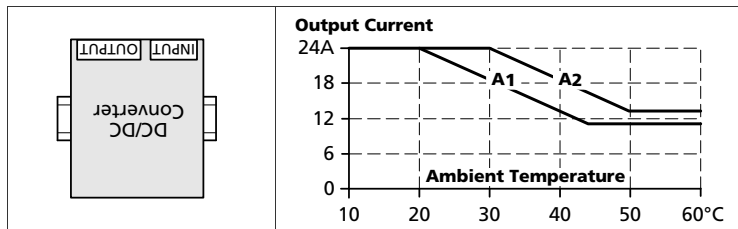

Fig. 22-7
Mounting Orientation C
(Table-top mounting)

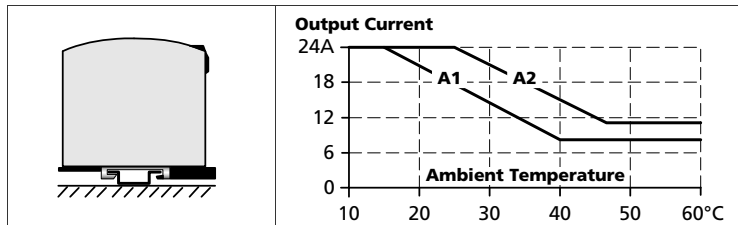

Fig. 22-8
Mounting Orientation D
(Horizontal cw)

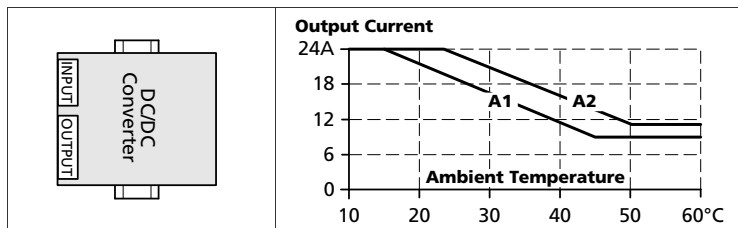

Fig. 22-9
Mounting Orientation E
(Horizontal ccw)

